

# QUBE 360

## Description

The QUBE 240 / 360 is the perfect choice for professional saunas.

### Innovative technology:

- Sauna heater capacity: 30 kW, 33 kW and 36 kW
- Exterior parts made of brushed and powder-coated stainless steel
- Interior parts made of stainless steel
- External control unit
- Heating rods and stone chamber separate from each other
- Easy to service due to detachable connection box
- 3-coating technology
- Adjustable feet



## Accessoires

**30-36 kW**  
**Heater railing lime wood**  
**(2 sided) preinstalled**  
 QUBE-L4

**Heater railing walnut**  
**(2 sided) preinstalled**  
 QUBE-W4

**Cable cover**  
 SAA00102



## Details

<b>Item number</b>	<b>1-049-850</b>
	<b>QUBE-360</b>
Color	black / stainless steel
Power rating [kW]	30 - 36
Cabine volume [m³]	40 - 65
Vaporator internal [kW]	No
Dimensions (BxTxH) [mm]	980 x 500 x 910-920
Weight [kg]	90
Stone weight [kg]	100
Supply voltage	400V 3N~ 400V 3~ (30kW)



# QUBE 360

## Safety distances

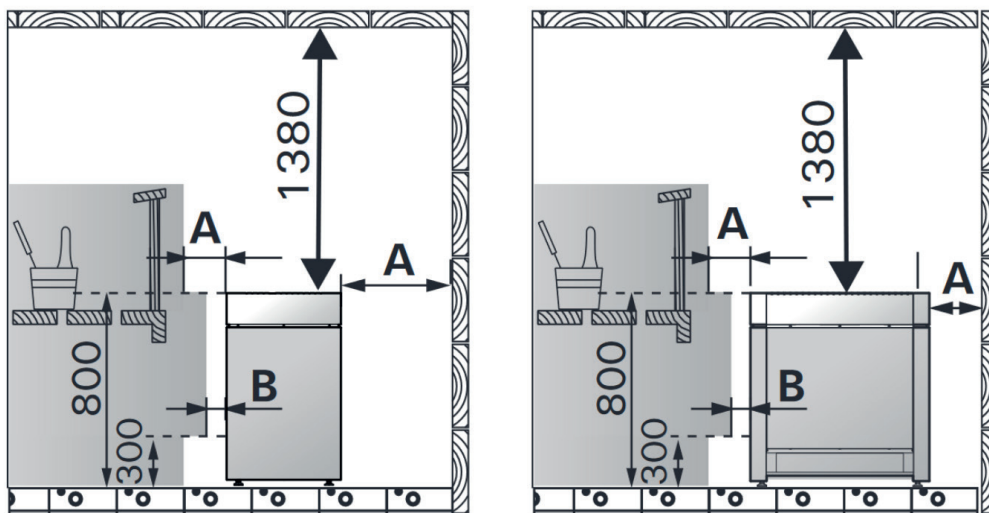

QUBE-360

A min. 150  
B min. 100

## Dimensions

QUBE-360

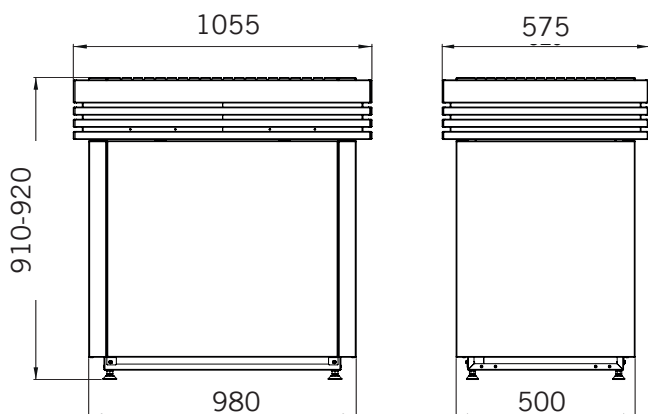

# QUBE 360

## Wiring diagrams

QUBE-360 (30 kW, 33 kW, 36 kW)

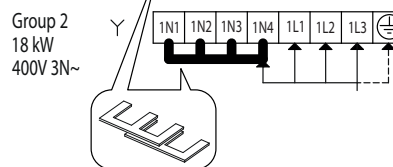
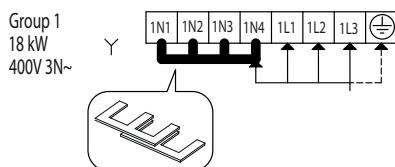
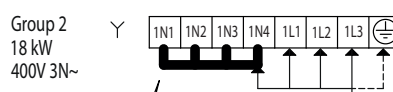
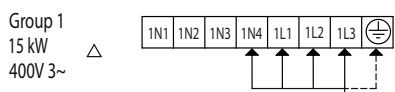
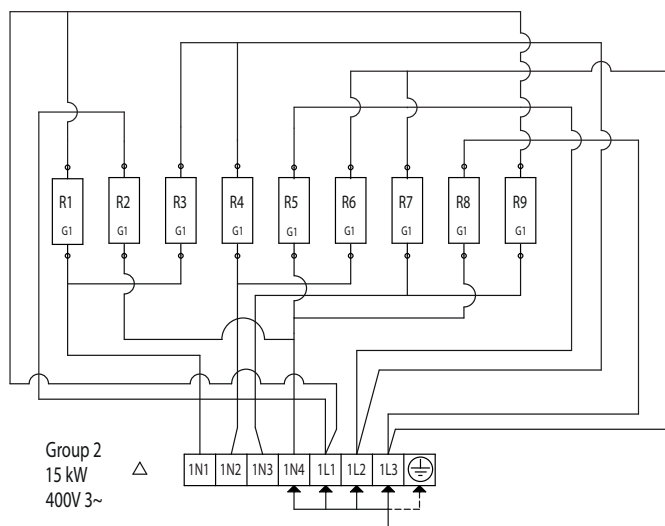
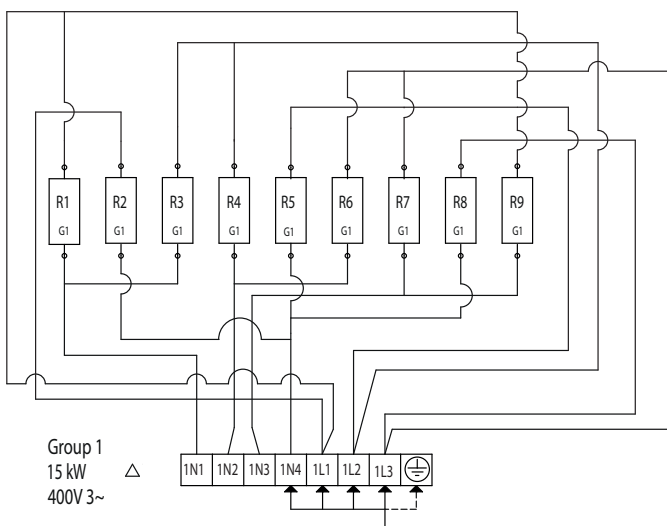

Model Modell	Output Leistung (kW)	Output Leistung (kW) group I Gruppe I	Output Leistung (kW) group II Gruppe II	Fuses Sicherungen group I Gruppe I (A)	Fuses Sicherungen group II Gruppe II (A)
Qube-360	30	15	15	3 x 25	3 x 25
	33	18	15	3 x 35	3 x 25
	36	18	18	3 x 35	3 x 35



# QUBE 360

## Beschreibung

Der Home Premium fin ist die perfekte Wahl bei professionellen Saunen.

### Innovative Technologie:

- Saunaofen Leistung: 30 kW, 33 kW und 36 kW
- Außenteile aus gebürstetem sowie pulverbeschichtetem Edelstahl
- Innenteile aus Edelstahl
- Externe Steuerung
- Heizstäbe und Steinkammer getrennt voneinander
- Servicefreundlich durch entnehmbaren Anschlusskasten
- 3-Mantel-Technik
- Höhenverstellbare FüÙe



## Zubehör

30-36 kW

Ofenreling Linde  
(2-seitig) vormontiert  
QUBE-L4

Ofenreling Nuss  
(2-seitig) vormontiert  
QUBE-W4

Kabelabdeckung  
SAA00102



## Details

Art.-Nr.	1-049-850
	<b>QUBE-360</b>
Farbe	schwarz / Edelstahl
Leistung [kW]	30 - 36
Kabinenvolumen [m³]	40 - 65
Verdampfer integriert [kW]	No
Abmessungen (BxTxH) [mm]	980 x 500 x 910-920
Masse [kg]	90
Steinmenge [kg]	100
Versorgung	400V 3N~ 400V 3~ (30kW)



# QUBE 360

## Sicherheitsabstände

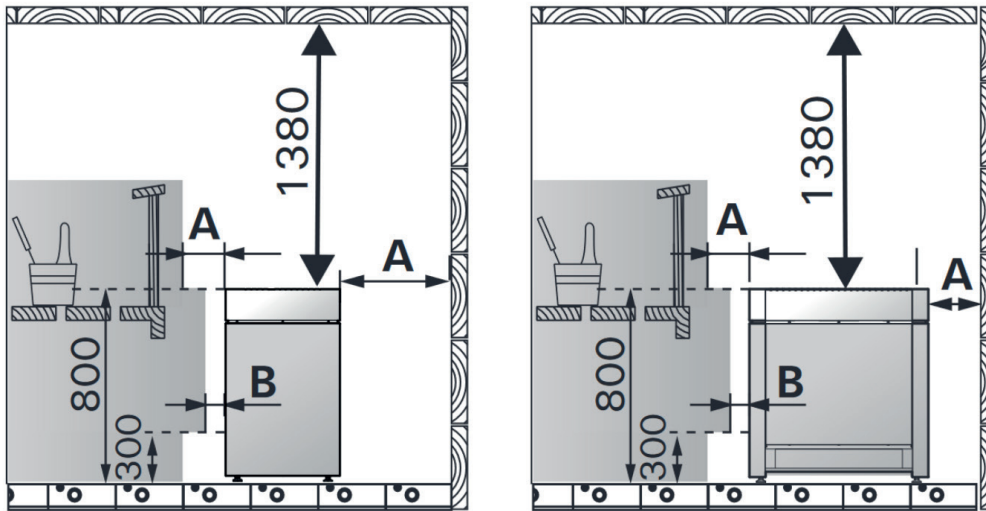

## Abmessungen

### QUBE-360

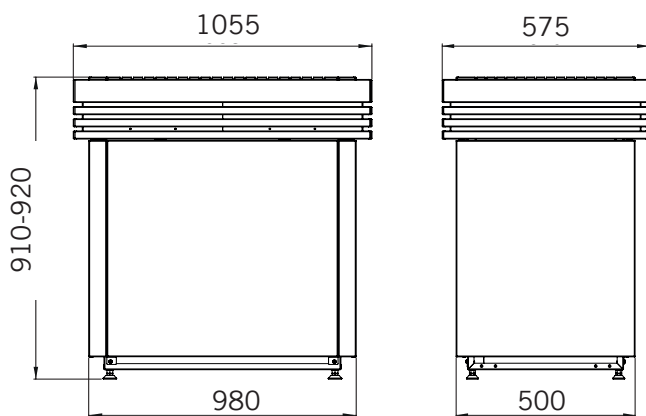

# QUBE 360

## Verdrahtungsschemen

QUBE-360 (30 kW, 33 kW, 36 kW)

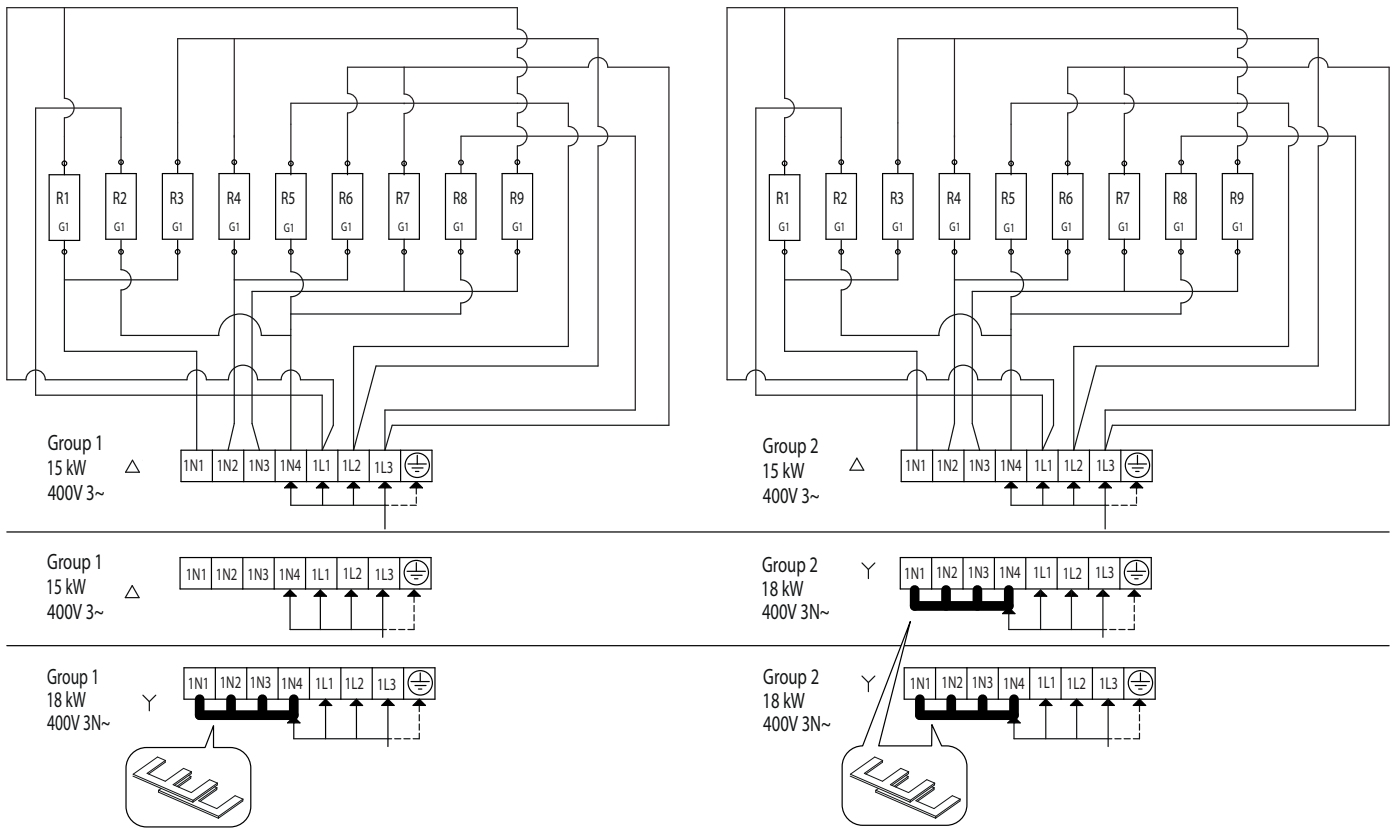

Model Modell	Output Leistung (kW)	Output Leistung (kW) group I Gruppe I	Output Leistung (kW) group II Gruppe II	Fuses Sicherungen group I Gruppe I (A)	Fuses Sicherungen group II Gruppe II (A)
Qube-360	30	15	15	3 x 25	3 x 25
	33	18	15	3 x 35	3 x 25
	36	18	18	3 x 35	3 x 35

